

# MT5 JB3 - JH3 - JHQ – 160 Nm 5-Speed Manual Transmissions

# JB3 - JH3 - JHQ - CUSTOMER BENEFITS

***These MT5 with optimized cost performance equip most of Renault gasoline mid range vehicles. They are produced in more than one million units per year.***

## DRIVING COMFORT

- Hydraulic clutch control or mechanical
- 1st -2nd double-cone synchronization
- Reverse gear brake
- Noise reduction thanks to reinforcement on gearbox housing

## PERFORMANCE AND CONSUMPTION

- Improved internal drag
- Spherical differential

## REMARKABLY COMPACT

- In the 2-shaft transmission category

## EASY ADAPTABILITY TO VEHICLE

- Cable control: on top of the JH3 and JHQ transmissions
- Rod: in bottom of the JB3 transmissions

## MAINTENANCE - TOTAL COST OF OWNERSHIP\*

- no maintenance, filled for life

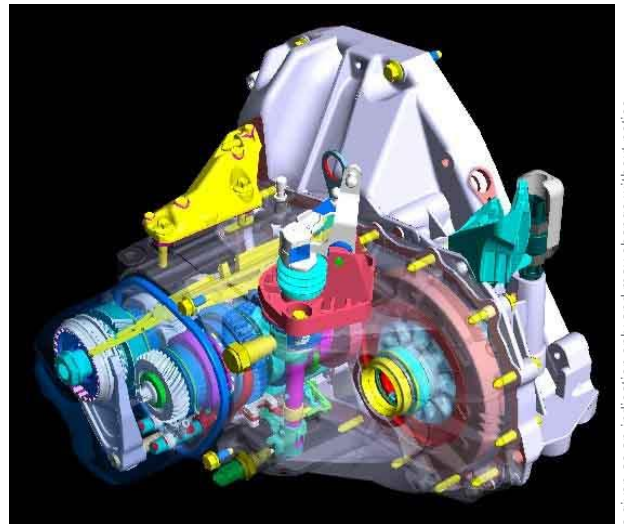

## SHIFTING PATTERN:

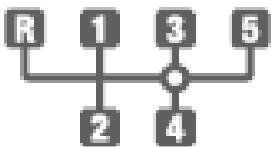

**JB3**

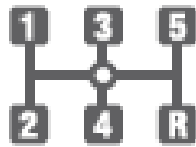

**JH3/JHQ**



## A WIDE RANGE OF APPLICATIONS

- A to B segment Cars
- Commercial Vehicles
- Equips Renault, Nissan and other vehicle manufacturers

\*On Renault vehicles under West Europe market conditions

\*\*Availability depends on required emission standards and vehicle characteristics

# JB3 - JH3 - JHQ - SPECIFICATIONS

## MAIN SPECIFICATIONS

	JB3/JH3	JHQ
Maximum Torque Capacity (Nm)	160	160
Maximum Speed (rpm)	6,500	6,500
Number of forward Speeds	5	5
Synchronisation	Single cones or 1st/2 <sup>nd</sup> double cones (option)	5 synchronised forward speeds
Dry Weight (kg)	32	34
Type of Clutch Operation	Mechanical	annular hydraulic (CSC)
Differential Material	Cast iron	Cast iron
Oil Capacity (liters)	3,4	2.5
Options	Reverse gear brake	Reverse gear braked 1st/2 <sup>nd</sup> double cones mechanical tachymeter

## OTHER SPECIFICATIONS

<b>Housing Material</b>	<b>Aluminum</b>
<b>Clutch Diameter (mm)</b>	<b>180 – 215</b>
<b>Oil Type</b>	<b>mineral or semi synthetic</b>
<b>Offset between Differential and Final Drive (mm)</b>	<b>183</b>
<b>Offset between Primary and Secondary Shaft (mm)</b>	<b>66</b>
<b>Synchromesh Material</b>	<b>Brass</b>

## GEAR RATIO EXAMPLES

	JB3	JB3	JH3	JH3	JHQ	JHQ
1st	11x37	11x41	11x41	11x41	11x41	11x37
2nd	22x41	21x43	21x43	21x43	21x43	21x41
3rd	28x37	28x39	28x39	28x37	28x39	28x37
4th	34x35	34x35	31x34	30x29	34x35	30x29
5th	39x32	39x31	37x33	42x31	39x32	42x31
Final drive	15x61	16x57	15x58	16x55	14x63	15x58
Energy	Gasoline	Diesel	Gasoline	Diesel	Gasoline	Diesel

# JB3 - JH3 - JHQ - MAIN DIMENSIONS

**JB3-JH3-JHQ Dimensions in mm**

	21°	25°
<b>A</b>	118	
<b>B</b>	274	
<b>C</b>	174	180
<b>D</b>	318	325
<b>E</b>	193	203
<b>F</b>	202	202
<b>G</b>	183	
<b>H</b>	21°	25°
<b>I</b>	-	-

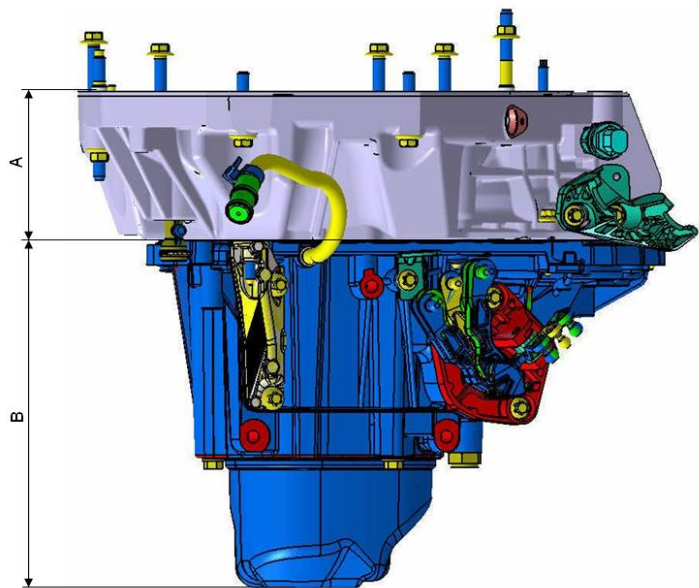
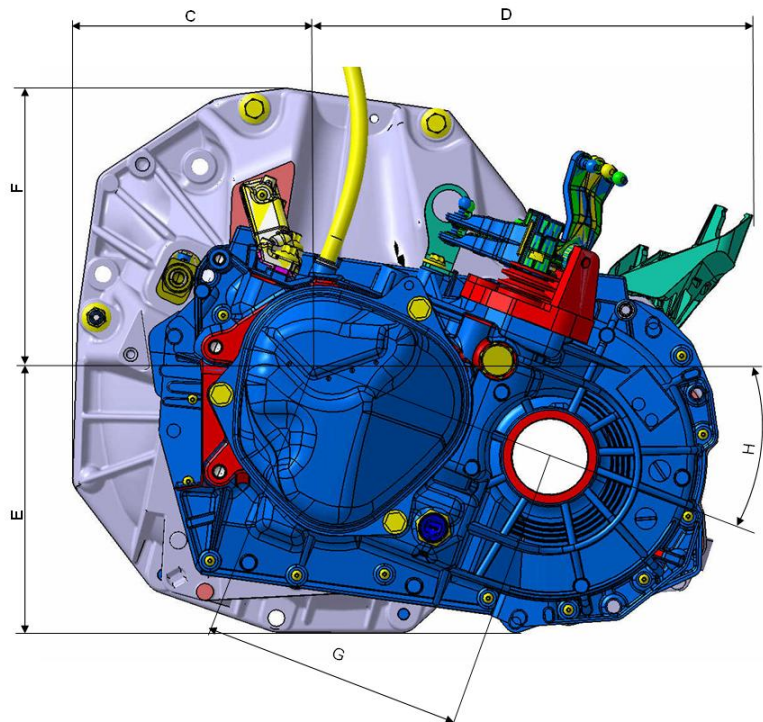

RP 06 2012 - The information in this brochure is given as an indication only and may change without notice

( [renault.powertrain@renault.com](mailto:renault.powertrain@renault.com) )

**RENAULT  
POWERTRAIN**

Renault Powertrain  
FR CTR A02 P 35  
67, rue des Bons Raisins - 92 508 Rueil Malmaison - France  
Tel : +33 (0)1 76 87 52 50 - Fax : +33 (0)1 76 86 96 94  
E-mail : [renault.powertrain@renault.com](mailto:renault.powertrain@renault.com)

**afaq**  
**ISO 9001**  
Qualité  
AFNOR CERTIFICATION