

F4R

2.0 16v - Gasoline Euro5

**RENAULT
POWERTRAIN**

DRIVE THE CHANGE



F4R - CUSTOMER BENEFITS

F4R 2.0 16v delivers high power and torque for outstanding performance. Driving can be both smooth and lively for a day-to-day use or fast paced with the Renault Sport RS Version.

TECHNOLOGY, LOW EMISSIONS

- Variable Valve Timing (VVT)
- High Torque at low speed
- Flex Fuel Version available E100
- LPG version available

DRIVING COMFORT - FUN TO DRIVE

- Power range: 88-145 kW
- Maximum torque: 191-215 Nm
- Sweetness and smoothness in normal driving, reactivity and sports used firmness

ENVIRONMENT FRIENDLY

- Up to Euro5 compliant

MAINTENANCE - TOTAL COST OF OWNERSHIP*

- Reliable engine
- Service 30,000 km

AVAILABLE TRANSMISSIONS

- 6 speeds Manual transmission
- Automatic Transmission

DRIVETRAIN LAYOUTS

- East-West available
- North-South to be studied by Renault



A RANGE OF APPLICATIONS

- B,C to D segment Cars
- LCV

*On Renault vehicles under West Europe market conditions

F4R - SPECIFICATIONS

MAIN SPECIFICATIONS

	2.0 16v	2.0 16v RS
Number of Cylinders	4	
Number of Valves	16	
Bore x Stroke (mm)	82.7 x 93	
Total Displacement (cc)	1998	
Max. Power, kW (HP)	103 (140)	147.5 (203)
Speed at max. Power (RPM)	5500	7100
Max. Torque Nm (lbf.ft)	191 (141)	215 (159)
Speed at max Torque (RPM)	3750	5400
Compression Ratio	9.8 :1	11.5:1
Fuel Injection	Sequential Multipoint	
Atmospherique	Yes	
Fuel	RON 95	
Emissions Standard	Euro5	
Dimensions (LxWxH)	644 x 689 x 717	
Weight (kg)	146	

OTHER SPECIFICATIONS

Cylinder Block Material	Cast Iron
Cylinder Head Material	Aluminum
Oil Sump Material	Aluminum
Emissions Control System	Catalyst
Power Steering	Hydraulic pump
Standard Engine Position	East-West, intake towards the front
Standard Engine Tilt	8° to 12° degrees towards exhaust
Electric Interface to vehicle	CAN Bus

F4R – PERFORMANCE AND MAIN DIMENSIONS

F4R

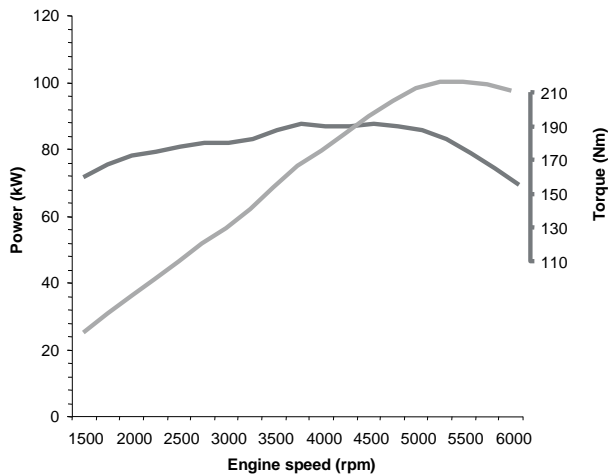

G	297
H	392
I	197
J	453
K	717

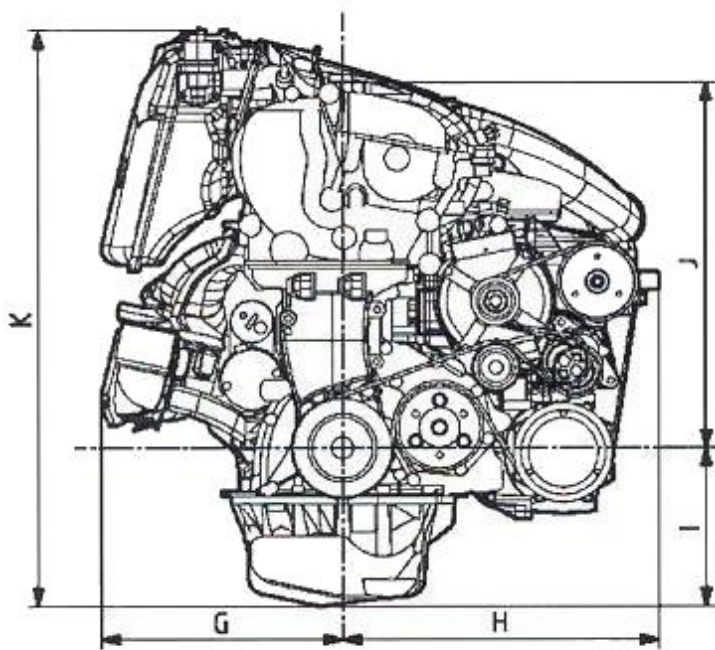

F4R RS

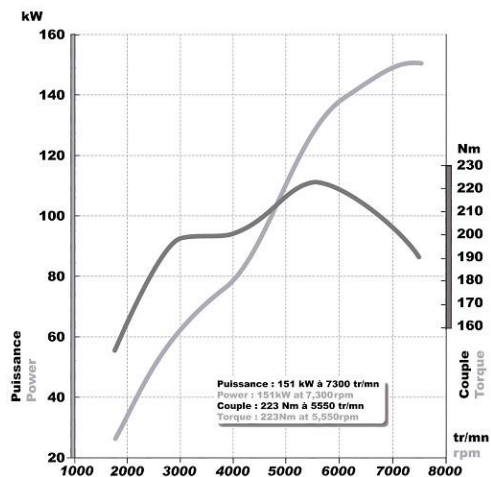

A	270
B	226
C	197
D	267
E	222
F	278

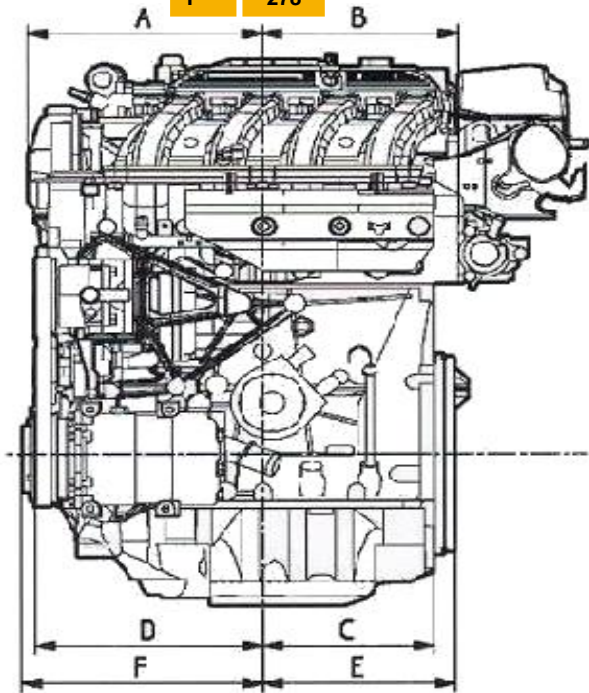

Dimensions in mm

(renault.powertrain@renault.com)

RENAULT
POWERTRAIN

Renault Powertrain
 FR CTR A02 P 35
 67, rue des Bons Raisins – 92 508 Rueil Malmaison – France
 Tel : +33 (0)1 76 87 52 50 – Fax : +33 (0)1 76 86 96 94
 E-mail : renault.powertrain@renault.com

afaq
ISO 9001
Qualité
AFNOR CERTIFICATION